

TEE TYPE STRAINERS

TEE STRAIGHT FLOW
"MODEL TS"
(DOUBLE RUNNER RODS ARE USED ON THIS
MODEL SO THAT FLOW REVERSAL WILL NOT
CREATE ANY PROBLEMS.)

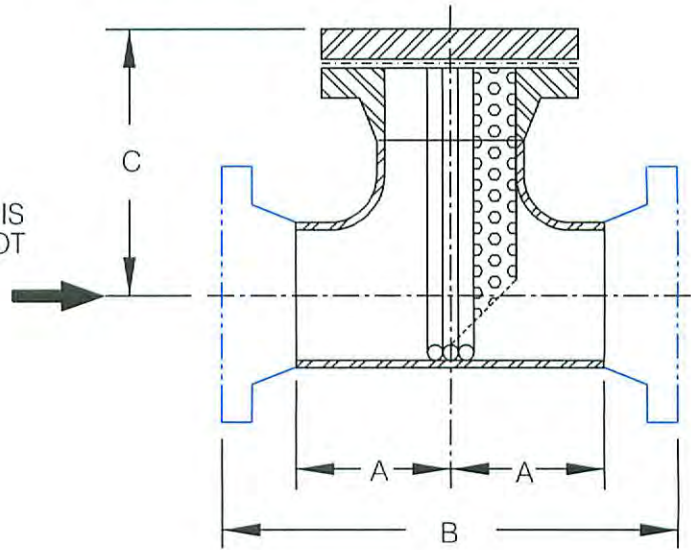

TEE ANGLE FLOW
"MODEL TA"

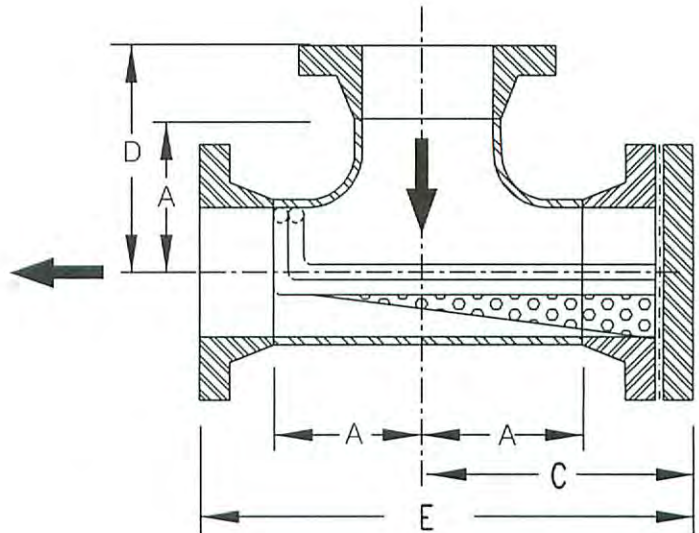

TEE ANGLE MODIFIED
(BI-DIRECTIONAL FLOW)
"MODEL TAM"

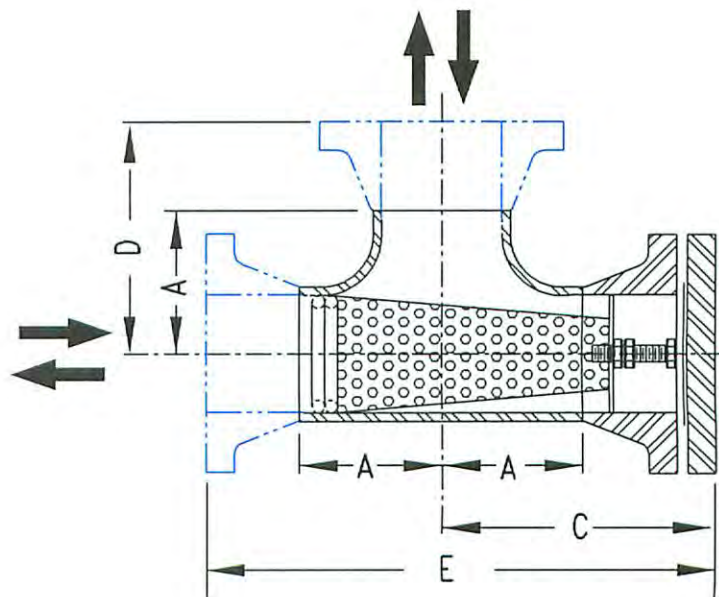

TEE TYPE STRAINERS

DIMENSIONAL DATA

PIPE SIZE	A	B					C				
		150#	300#	600#	900#	1500#	150#	300#	600#	900#	1500#
2"	2 1/2"	10 1/4"	10 3/4"	11 1/2"	13 3/4"	13 3/4"	6"	6 3/8"	7 1/8"	8 3/4"	8 3/4"
2.5"	3"	11 3/4"	12 1/4"	13"	15"	15"	6 7/8"	7 1/4"	8"	9 1/2"	9 1/2"
3"	3 3/8"	12 1/2"	13 1/4"	14"	15 1/2"	16 3/4"	7 5/16"	7 7/8"	8 5/8"	9 5/8"	10 5/8"
4"	4 1/8"	14 1/2"	15 1/4"	17"	18"	18 3/4"	8 5/16"	9"	10 1/2"	11 1/8"	11 7/8"
5"	4 7/8"	17"	17 3/4"	19 1/2"	20 1/2"	22 3/4"	9 9/16"	10 3/8"	11 7/8"	12 5/8"	14 5/8"
6"	5 5/8"	18 1/2"	19 1/4"	21 1/4"	23"	25 1/2"	10 3/8"	11 3/16"	12 7/8"	14 1/16"	16 3/8"
8"	7"	22 1/4"	23"	25 1/4"	27 1/2"	31 1/2"	12 3/8"	13 1/4"	15 3/16"	16 5/8"	19 3/4"
10"	8 1/2"	25 1/4"	26 1/2"	29 3/4"	32 1/4"		13 15/16"	15 1/4"	17 3/4"	19 1/4"	
12"	10"	29 1/4"	30 1/2"	33"	36 1/2"		16"	17 3/8"	19 1/2"	21 3/4"	
14"	11"	32 1/4"	33 1/2"	35 3/4"			17 5/8"	19"	21"		
16"	12"	34 1/4"	35 3/4"	38 3/4"			18 11/16"	20 1/4"	22 3/4"		
18"	13 1/2"	38 1/4"	39 3/4"	42 1/4"			20 13/16"	22 3/8"	24 3/4"		
20"	15"	41 5/8"	43"	45 3/4"			22 5/8"	24 1/8"	26 3/4"		
24"	17"	46 1/4"	47 1/2"	50 3/4"			25 1/8"	26 5/8"	29 3/4"		
PIPE SIZE		D					E				
		150#	300#	600#	900#	1500#	150#	300#	600#	900#	1500#
2"	2 1/2"	5 1/8"	5 3/8"	5 3/4"	6 7/8"	6 7/8"	11 1/8"	11 3/4"	12 5/8"	15 3/8"	15 3/8"
2.5"	3"	5 7/8"	6 1/8"	6 1/2"	7 1/2"	7 1/2"	12 3/4"	13 3/8"	14 1/4"	16 5/8"	16 5/8"
3"	3 3/8"	6 1/4"	6 5/8"	7"	7 3/4"	8 3/8"	13 9/16"	14 1/2"	15 3/8"	17 1/8"	18 3/4"
4"	4 1/8"	7 1/4"	7 5/8"	8 1/2"	9"	9 3/8"	15 9/16"	16 5/8"	18 5/8"	19 7/8"	20 3/4"
5"	4 7/8"	8 1/2"	8 7/8"	9 3/4"	10 1/4"	11 3/8"	18 1/16"	19 1/4"	21 3/8"	22 5/8"	25 3/4"
6"	5 5/8"	9 1/4"	9 5/8"	10 5/8"	11 1/2"	12 3/4"	19 5/8"	20 13/16"	23 1/4"	25 5/16"	28 7/8"
8"	7"	11 1/8"	11 1/2"	12 5/8"	13 3/4"	15 3/4"	23 1/2"	24 3/4"	27 9/16"	30 1/8"	35 1/4"
10"	8 1/2"	12 5/8"	13 1/4"	14 7/8"	16 1/8"		26 9/16"	28 1/2"	32 3/8"	35 1/8"	
12"	10"	14 5/8"	15 1/4"	16 1/2"	18 1/4"		30 5/8"	32 5/8"	35 3/4"	39 3/4"	
14"	11"	16 1/8"	16 3/4"	17 7/8"			33 3/4"	35 3/4"	38 5/8"		
16"	12"	17 1/8"	17 7/8"	19 3/8"			35 13/16"	38 1/8"	41 7/8"		
18"	13 1/2"	19 1/8"	19 7/8"	21 7/8"			39 15/16"	42 1/4"	45 5/8"		
20"	15"	20 13/16"	21 1/2"	22 7/8"			43 7/16"	45 5/8"	49 3/8"		
24"	17"	23 1/8"	23 3/4"	25 3/8"			48 1/4"	50 3/8"	54 7/8"		

DIMENSIONS SHOWN ARE (REFERENCE DIMENSIONS) FOR ESTIMATING PURPOSES ONLY.
 ACTUAL DIMENSIONS WILL BE PROVIDED ON "AS-BUILT" DRAWINGS, AVAILABLE WITH ORDER.
 THE DIMENSIONS ABOVE ARE ONLY APPLICABLE WITH RAISED FACE WELD NECK (RFWN) FLANGES.
 DIMENSIONS 'C' AND 'E' INCLUDES 1/8" THK GASKET THICKNESS AND 1/8" WELD GAP.

BASE MATERIALS FOR STRAINERS

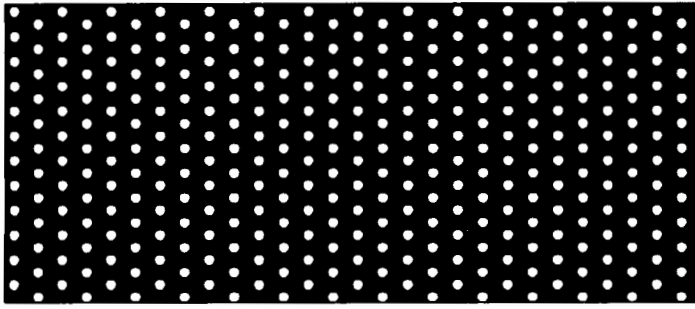

1/16"∅ on 1/8" ctrs.

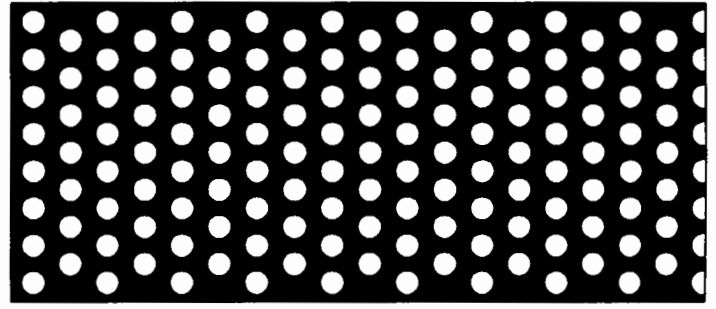

1/8"∅ on 3/16" ctrs.

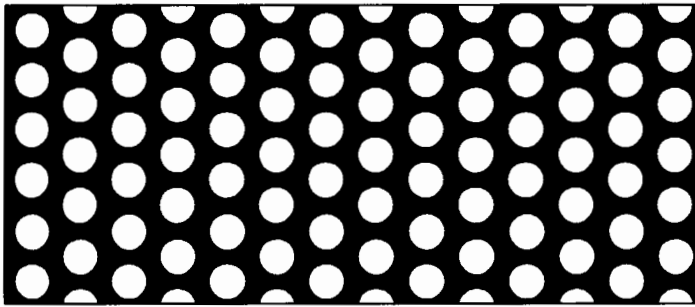

3/16"∅ on 1/4" ctrs.

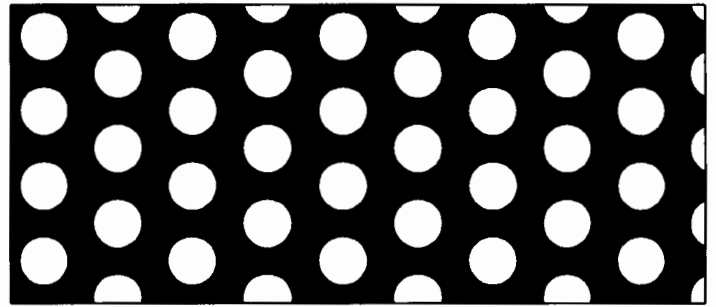

1/4"∅ on 3/8" ctrs.

PERFORATED MATERIALS

Gage	Perforation	Holes/sq. in.	% of Open Area	Material Range
20	1/16"∅ on 1/8" ctrs.	74.0	22.7%	Carbon Steel, 304SS, 316SS
16	1/8"∅ on 3/16" ctrs.	33.0	40.3%	Carbon Steel, 304SS, 316SS 304L, 316L, Monel
16	3/16"∅ on 1/4" ctrs.	18.5	51.0%	Carbon Steel, 304SS, 316SS
16	1/4"∅ on 3/8" ctrs.	8.0	40.3%	Carbon Steel, 304SS, 316SS
14	1/8"∅ on 3/16" ctrs.	33.0	40.3%	Carbon Steel, 304SS, 316SS
14	3/16"∅ on 1/4" ctrs.	18.5	51.0%	Carbon Steel, 304SS, 316SS
14	1/4"∅ on 3/8" ctrs.	8.0	40.3%	Carbon Steel, 304SS, 316SS
12	1/8"∅ on 3/16" ctrs.	33.0	40.3%	Carbon Steel
11	1/8"∅ on 3/16" ctrs.	33.0	40.3%	304SS, 316SS
11	1/4"∅ on 3/8" ctrs.	8.0	40.3%	Carbon Steel, 304SS, 316SS

OTHER PERFORATIONS AVAILABLE UPON REQUEST.

WIRE MESH TYPE BASE MATERIAL (Available From Stock)

Mesh	Wire Diameters		Width of Opening		% of Opening	Material Range
	in.	mm.	in.	mm.		
2	.063	1.6	.437	11.10	76.4%	Carbon Steel, 304SS, 316SS
3	.063	1.6	.270	6.86	65.5%	Carbon Steel, 304SS, 316SS
4	.063	1.6	.187	4.75	56.0%	Carbon Steel, 304SS, 316SS
5	.063"	1.6	.137	3.48	46.9%	Carbon Steel, 304SS, 316SS
6	.047	1.19	.120	3.50	51.8%	Carbon Steel, 304SS, 316SS
8	.047	1.19	.078	1.98	38.9%	Carbon Steel, 304SS, 316SS

OTHER SIZES AND MATERIALS AVAILABLE UPON APPLICATION.

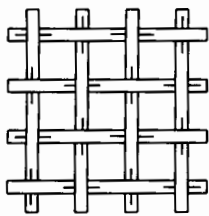

4 Mesh
.072

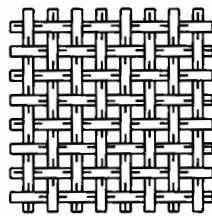

8 Mesh
.047

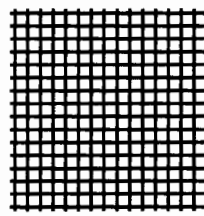

10 Mesh
.025

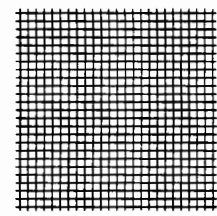

20 Mesh
.016

WIRE MESH LINER MATERIAL (Available From Stock)

Mesh	Wire Diameters		Width of Opening		% of Opening	Material Range
	in.	mm.	in.	mm.		
10	.025	.640	.075	1.91	56.3%	304SS, 316SS
20	.016	.406	.034	.86	46.2%	304SS, 316SS
30	.013	.330	.020	.52	37.1%	304SS, 316SS
40	.010	.254	.015	.38	36.0%	304SS, 316SS
50	.009	.229	.011	.28	30.3%	304SS, 316SS
60	.0075	.191	.009	.23	30.5%	304SS, 316SS
80	.0055	.140	.007	.19	31.4%	304SS, 316SS
100	.0045	.114	.006	.14	30.3%	304SS, 316SS

OTHER SIZES AND MATERIALS AVAILABLE UPON APPLICATION.

RADAFAB TEE STRAINER OPEN AREAS

		T.S.			T.A.			T.A.M.		
LINE SIZE	SQ. IN. OF PIPE	GROSS SQ. IN.	% OF OPEN AREA	% INCREASE PER 1" ADDED TO LENGTH	GROSS SQ. IN.	% OF OPEN AREA	% INCREASE PER 1" ADDED TO LENGTH	GROSS SQ. IN.	% OF OPEN AREA	LENGTH
2	3.36	15	179	29.4	14	171	47	22	262	5 3/4"
2.5	4.79	21	177		20	195	43			
3	7.39	30	162	11.5	30	193	34	48	260	7 3/4"
4	12.73	48	151	16.6	51	189	27	83	261	9 3/4"
6	28.9	96	133	11.3	105	177	18	167	231	13"
8	50	158	126	8.4	178	185	14	278	222	16"
10	78.6	237	120	6.9	275	190	11	433	220	19 1/2"
12	113.1	336	119	5.8	397	189	9	619	219	23"
14	138	408	118	5.2	476	198	8	766	222	25 1/2"
16	183	521	114	2.6	606	196	7	183	209	27 1/2"
18	234	664	114	4	791	193	7	1223	209	31"
20	291	805	111	3.6	970	190	6	1513	208	34 1/4"
24	425	1130	106	3	1185	179	5	2064	194	38 1/2"

NOTES:

- 1.) BASED ON PERFORATED PLATE WITH OPEN AREA RATIO OF 40.3% (e.g. 1/8" DIA. HOLES ON 3/16" CENTERS).
- 2.) ALL VALUES ARE APPROXIMATE.
- 3.) REDUCE BY 15% IF MESH IS ADDED.

CORRECTION FACTOR:
 FOR LIQUIDS MORE VISCOUS THAN WATER
 OR WHERE WIRE CLOTH LINER IS ADDED
 MULTIPLY PRESSURE IN CHARTS BY:

VISCOSITY (SSU)	PERFORATED (1/8" HOLES)	PERFORATED W/ WIRE CLOTH		
		40 MESH	60 MESH	80 MESH
30	1.00	1.32	1.53	1.62
270	1.30	1.61	1.83	2.00
385	1.44	1.76	2.00	2.20
500	1.58	1.92	2.13	2.41
1000	1.66	2.22	2.41	2.63
2000	1.86	2.41	2.72	2.91

TEE TYPE STRAINERS PRESSURE DROP FOR LIQUIDS

(Perforated basket 1/8" dia. holes on 3/16" centers)

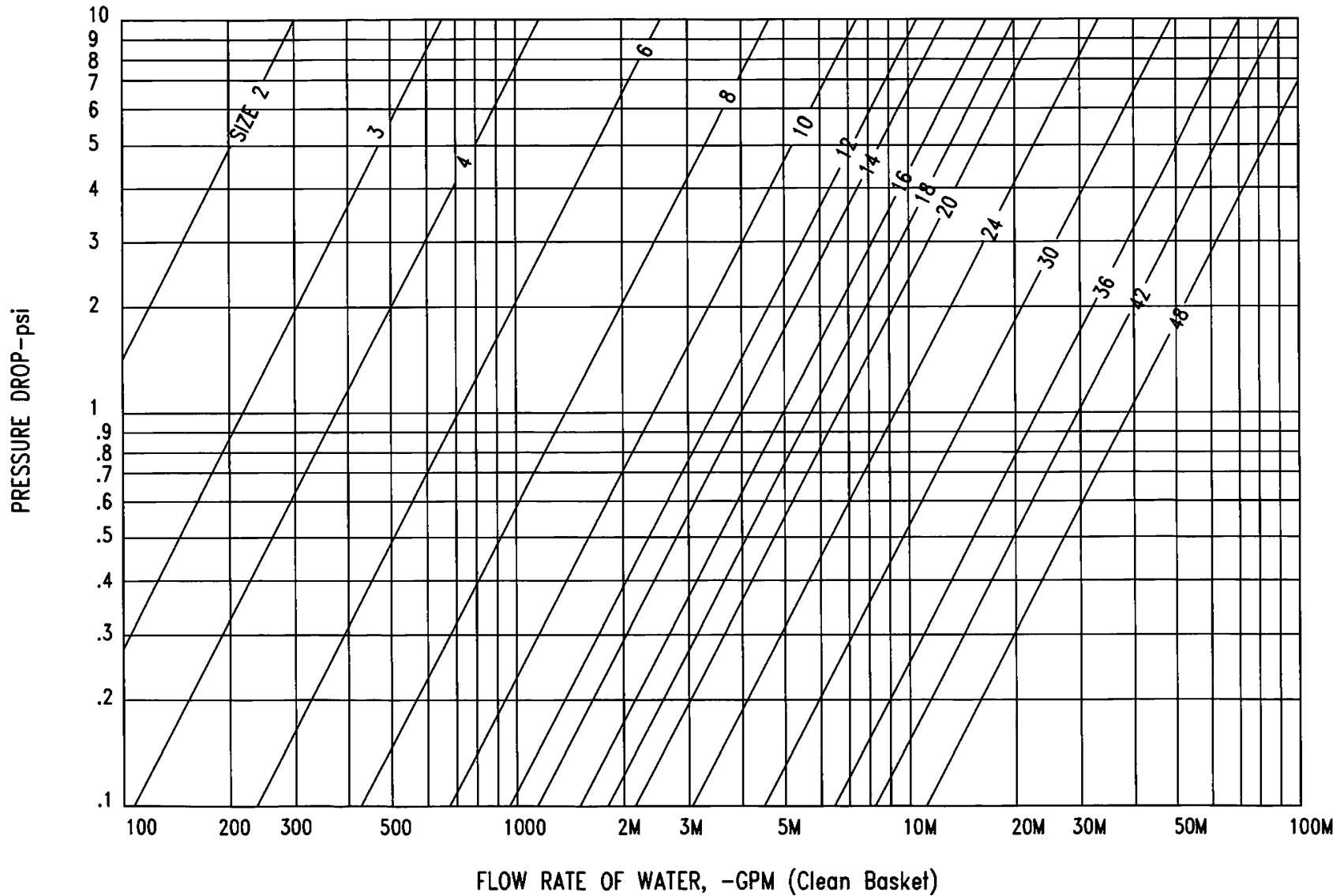

Certificate of Authorization Permit

Quality Management System

Expiry Date: **November 4, 2017**

Reg. No.: **AQP-1181**

RADAFAB OILFIELD & INDUSTRIAL SUPPLY INC.

7225 - 108 AVENUE S.E.
CALGARY, ALBERTA

having complied with the provisions of the SAFETY CODES ACT, is hereby authorized to perform the activities identified in the following table:

	<u>Construction</u>	<u>Repair</u>	<u>Alter</u>
Pressure Vessels			
ASME Section VIII-1 Pressure Vessels	Shop	Shop	Shop
Indirect Fired Heater Coils			
ASME B31.3 Indirect Fired Heater Coils	Shop	Shop	Shop
Pressure Piping			
ASME B31.3 Process Piping	Shop	Shop	Shop
Fittings			
Category A,E,H	Shop	Shop	Shop

As a condition of this permit, the holder is required to participate in interim audits by a safety codes officer to verify that the quality management system is being maintained in a manner acceptable to a safety codes officer.

Dated at Edmonton, this 30th day of July, 2014

Chief Inspector and Administrator

Certificate No.: 10064